



# Assembly, Installation, Operation and Maintenance Instructions

**P/N: 32556**

## 2014 to 2015 Dodge 2500 4 Bolt Custom Installation Bracket Kit.

**Dealer / Installer:** Provide a copy of these Instructions to the end user of this product. These Instructions provide important operating and safety information for proper usage of this product. Demonstrate the proper use of the product with the end user. Have the end user demonstrate that they understand the proper use of the product. Please refer to the husky weight demonstrator at:  
<http://www.huskytow.com/product-support/?dir=Literature/>. (requires Microsoft excel)

**End User:** Read and follow all instructions included in this manual. Ask your Dealer / Installer for assistance if you do not understand the proper use of the product. Never remove any decals from the product.

Use with 4 bolt 31323 or 10 bolt 30686 base rails. Base Rails are not included with this kit.

**Important! If you have the OEM 5<sup>th</sup> Wheel Prep. Package, you will have to remove the 2 rear “pucks” from the frame before proceeding with this installation.**

Center Bolt Kit 32059 must be used when towing with 26K hitch, Goose Neck or a Maneuvering System (not included).

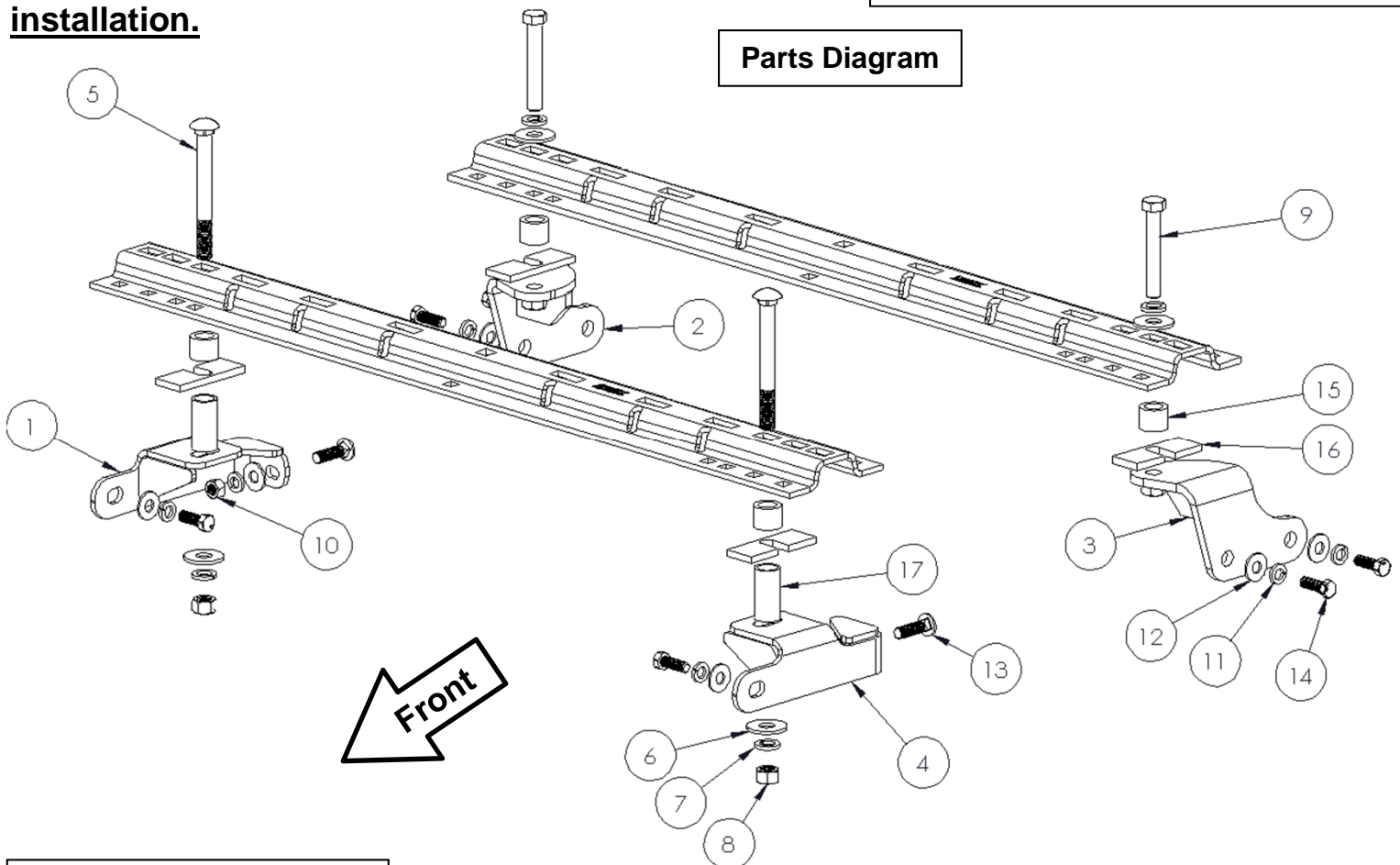

### **Hardware Torque Values:**

12mm to 70 lb-ft  
1/2" to 75 lb-ft  
5/8" to 150 lb-ft

## **TOOLS**

3/16" & 11/16" drill bits.

5/8" Transfer Center Punch.

1-1/4" hole saw.

18mm, 3/4" & 15/16" Socket & Open End Wrench.

Torque Wrench capable of 150 lb-ft.

1. The following instructions should be used to mount the fifth wheel. Care and attention to detail will ensure a quick quality installation. Check parts against parts list to become familiar with parts in kit.
2. Raise rear of truck high enough to allow jack stands to be placed under rear spring hanger bracket of truck. This will provide maximum room to install the fifth wheel brackets.

### **WARNING:**

**If the truck is raised, be sure that the truck is properly blocked and restrained to prevent the truck from falling. Failure to do so may result in the truck suddenly falling, causing death or serious injury.**

3. **Do NOT install mounting rails over plastic bed liners.** Plastic bed liners must be cut out of the way. Base rails may be installed on dry/cured spray in liner. **Note: Consult installer for recommended curing time.**
4. Use only the supplied bolts, nuts, and washers to install this kit. All nuts and bolts are Grade 5 unless specified otherwise.

### **CAUTION:**

**These instructions are guidelines only. Actual installation is the responsibility of the installer and the owner. Always measure truck and trailer before installing hitch to be sure that there is clearance at the cab and at the bumper to allow for turns.**

5. Measurements are given from rear edge of truck bed to rear edge of the base rail closest to the rear edge of truck for most vehicle applications.
6. Center hitch between fender wells and make sure rails are square. Adjust position of rails until both diagonal measurements are the same. This should allow installation of a gooseneck or other fifth wheels to these rails.

### **CAUTION:**

**Check for obstructions before drilling. Failure to do so could result in damaged fuel or brake lines, structural members, etc. HUSKY TOWING PRODUCTS does its best to communicate tow vehicle manufacturer changes; however, it is ultimately the responsibility of the installer to prevent damage due to installation.**

<b>PARTS LIST</b>		
<b>ITEM NO.</b>	<b>DESCRIPTION</b>	<b>QTY.</b>
1	PASSENGER SIDE FRONT BRACKET	1
2	PASSENGER SIDE REAR BRACKET	1
3	DRIVER SIDE REAR BRACKET	1
4	DRIVER SIDE FRONT BRACKET	1
5	5/8"-11 UNC X 6" CARRIAGE HEAD BOLT	2
6	5/8" FLAT WASHER	4
7	5/8" LOCKWASHER	4
8	5/8" -11 GR5 HEX NUT	2
9	5/8"-11 UNC X 4" HEX BOLT	2
10	1/2"-13 UNC HEX NUT	2
11	1/2" LOCK WASHER	8
12	1/2" FLAT WASHER	8
13	1/2"-13 X 1-3/4", GR5 CARRIAGE BOLT	2
14	M12-1.5 X 35MM GR8.8 HEX BOLT	6
15	BASE RAIL SPACER TUBE	4
16	1/4" SPACER PLATE	4
17	1-1/8" SPACER TUBE	2

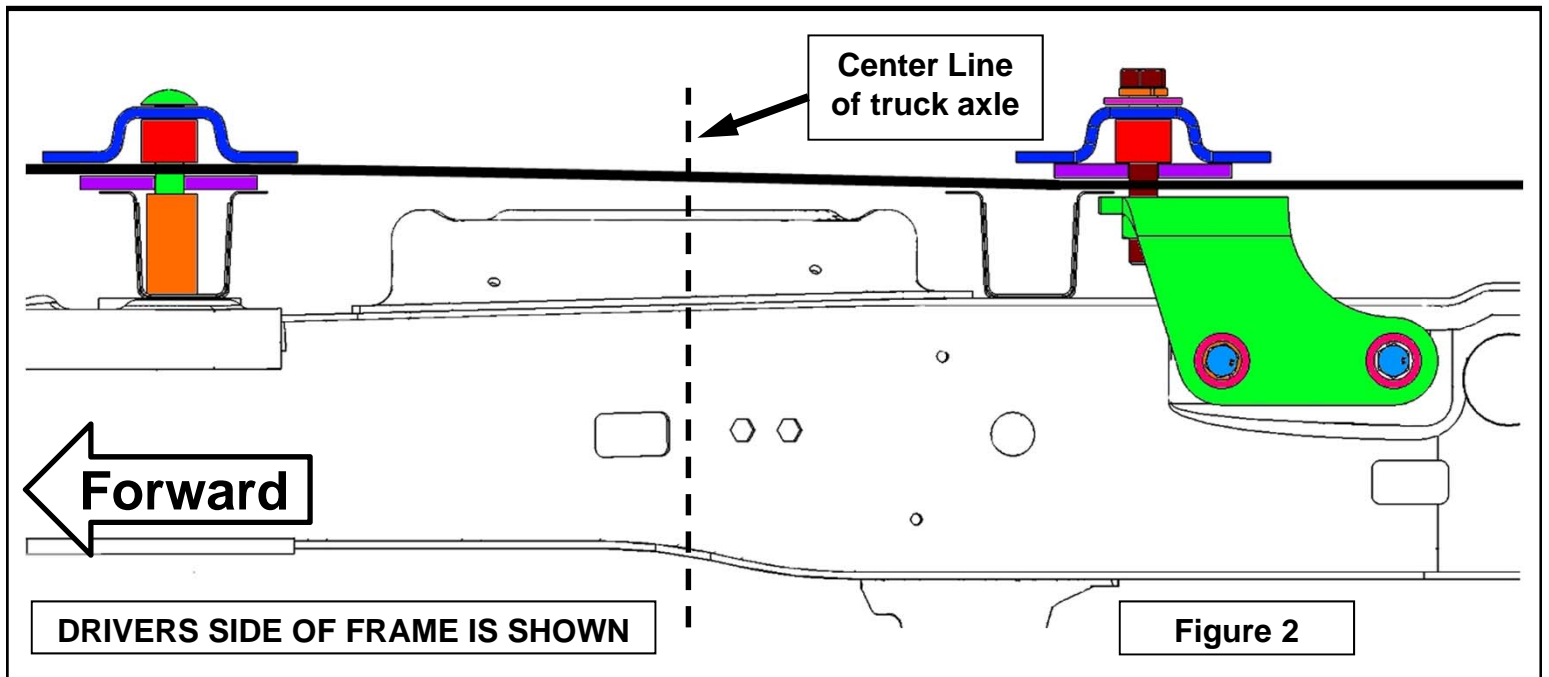
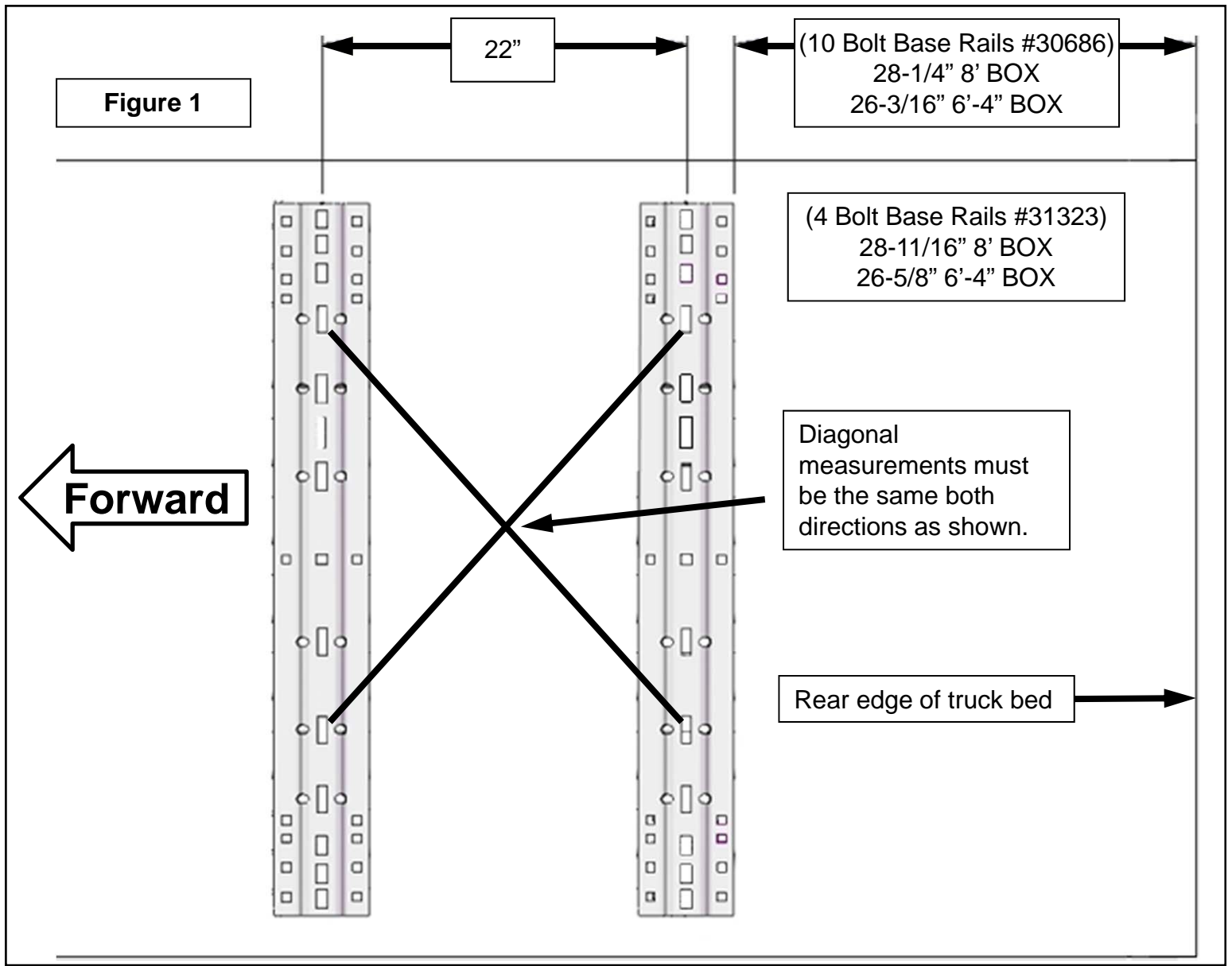

7. The wheel well liners will need to be removed to access the frame for bracket installation.
8. There are 8 screws along the inner edge of the wheel well fender flange and 2 screws in a recessed pocket on either side of the removable panel. Remove these 10 screws and carefully remove the wheel well liner and set aside with the screws to be re-installed later. (see Figure 3)
9. Repeat steps 7 & 8 for the opposite side.



**DRIVERS SIDE SHOWN**

**Figure 3**

10. Place the two bed rails across the truck bed between the wheel wells. Position the 5th wheel uprights between the bed rails so that the tabs in the base of each upright will fit into the slots in the ends of the bed rails. Secure the uprights in place with the rail hitch pins and hair pins supplied with the 5<sup>th</sup> wheel installation kit. Securely attach 5th wheel cross member to uprights.

11. On most applications, the 5th wheel assembly should be positioned so that it is approximately centered over the truck axle and between the wheel wells on the bed floor. See Figure 2 on page 3.

**NOTE:** To keep the trailer from hitting the cab on tight turns there must be at least 52" between the hitch and the cab. On long bed pickups the hitch center line can be up to 3" ahead of the axle. On short bed pickups this position is not possible. A 5th wheel hitch that can move the trailer rearward away from the truck cab should be used with a pickup truck bed length less than 8 ft, consult the Husky Towing Products catalog to select the product that best matches your needs.

12. When hitch is correctly positioned in the bed and the bed rails are parallel. See Figure 1 for measurements. Mark four attachment points on the truck bed using the 5/8" rectangular slots at the ends of each bed rail as a guide. The use of a 5/8" transfer center punch will ensure that the marks are correctly marked on the bed floor. Check below the bed before drilling holes to see that all wiring, brake lines or other obstructions are moved out of the way and will not be contacted by the drill bit. See Figure 4.

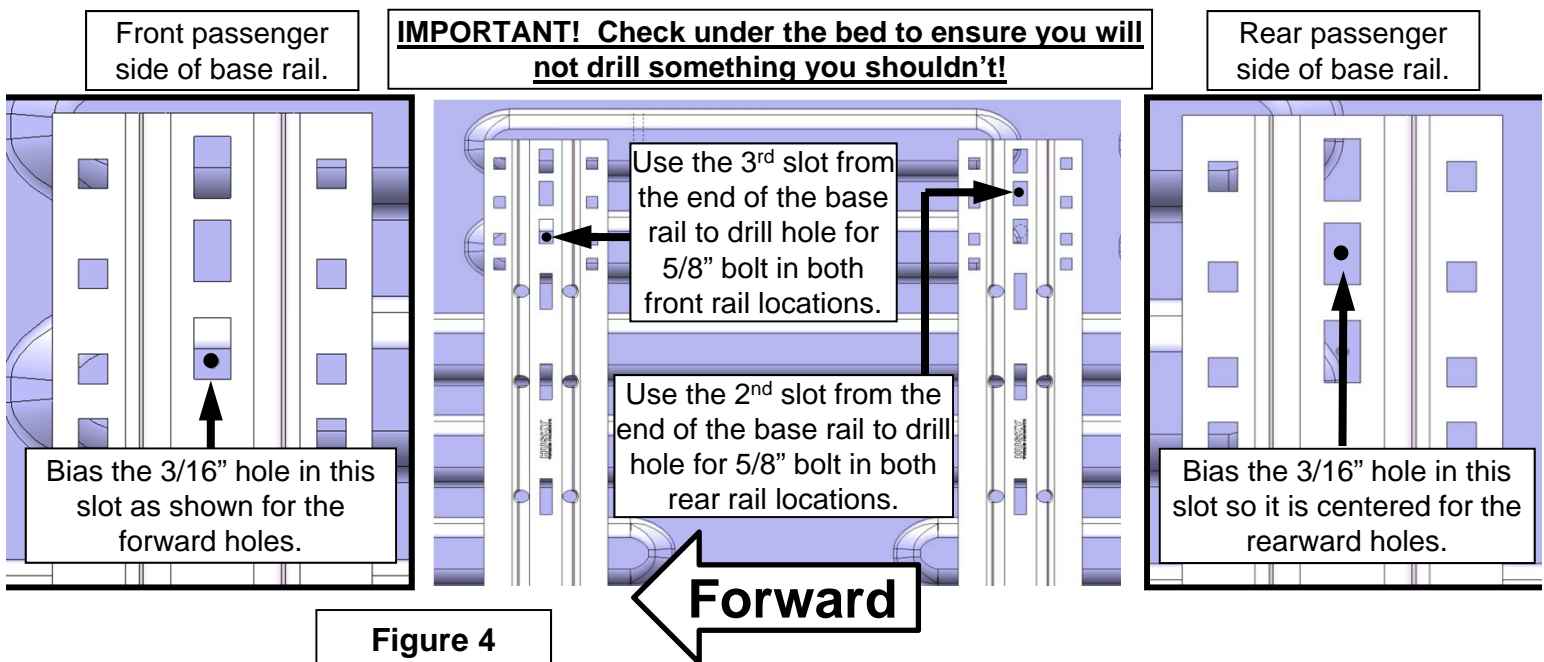

**Use EXTREME care when drilling the forward driver's side holes. Brake lines and wiring are very close to this location.**

13. Move the hitch assembly out of the way and drill four (4) 3/16" diameter pilot holes down through the bed at the previously marked points. Drill the 2 forward holes and be sure to drill through the bottom of the bed support channel. Check under the bed where the (4) 3/16" pilot holes are and ensure that when the brackets are placed up against the frame and line up with the mounting holes. See Parts Diagram for bracket locations and Figure 8 for detail work for driver's side front bracket

On the driver side front bracket, there are some preparations to be done before installation can proceed.  
See Figures 5, 6 & 7.

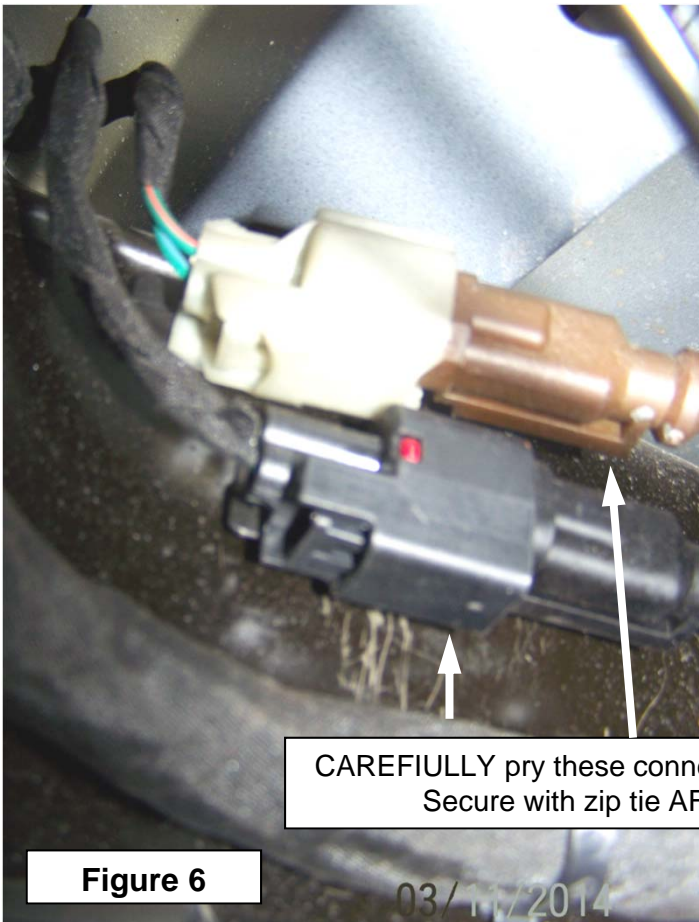
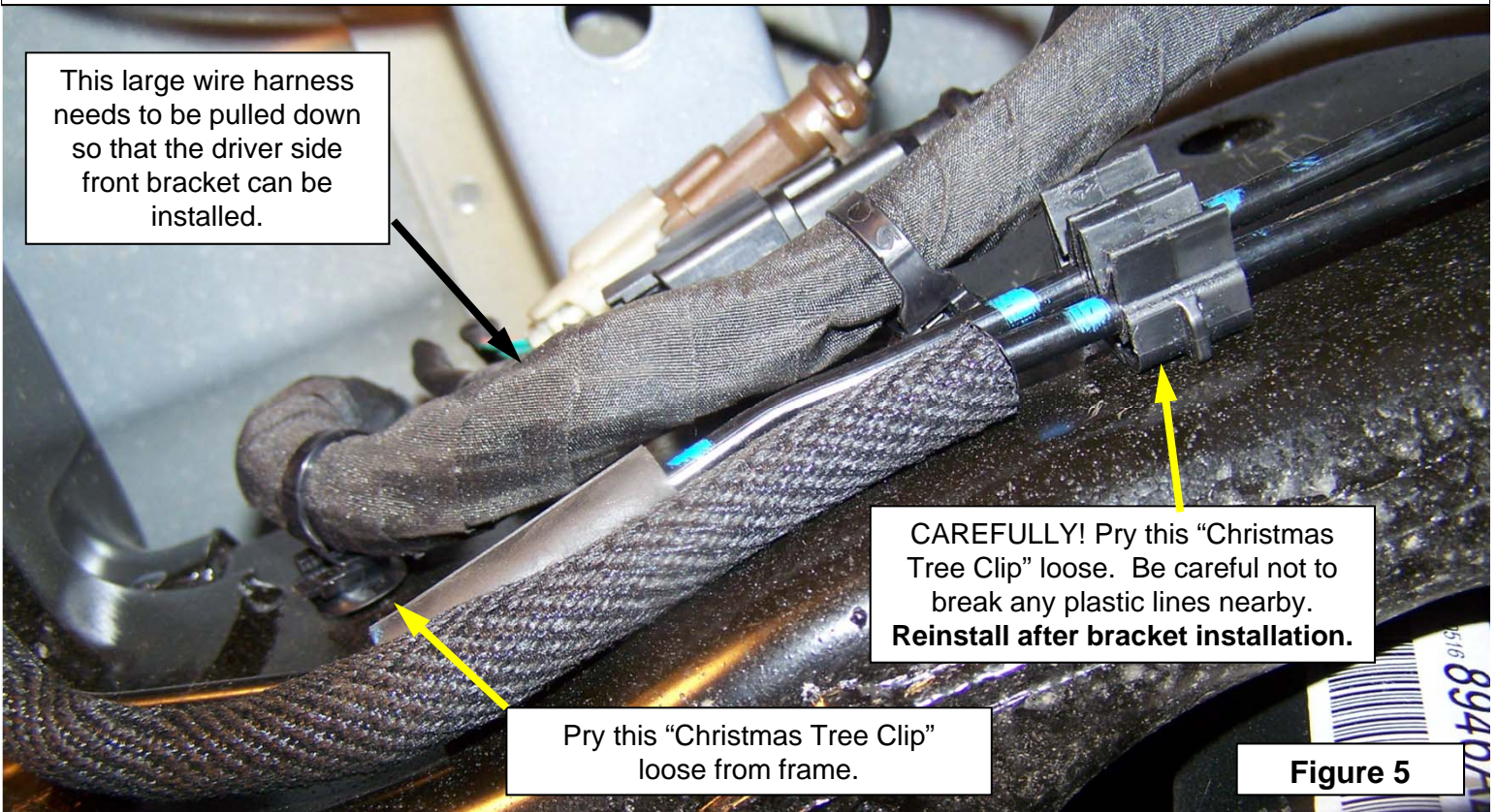

14. Using the 1-1/4" hole saw, cut the forward 2 holes out through the TRUCK BED ONLY. Then, switch to the 11/16" drill bit and drill the 11/16" hole in the bottom of the bed channel out using the 3/16" holes as a guide.

15. Insert the long tube spacer (item #17) into the forward holes. Then slide spacer plate (item #16) under the bed corrugation but above the bed support channel. Figure 4 shows the proper components assembly. See Figure 8. Truck bed not shown for clarity reasons.

16. Install front driver's side bracket (item #4) using the 12mm bolt and 1/2" washers shown (items #11,12 &14) through front slot of bracket. See Figure 9. Hand tighten only.

17. Install 1/2" fasteners into the rear hole of the front driver's side bracket using the 1/2" fasteners (item #10, 11, 12 & 13). 1/2" carriage bolt (#13) must be installed through the slot in the cross frame of the truck. Hand tighten only.

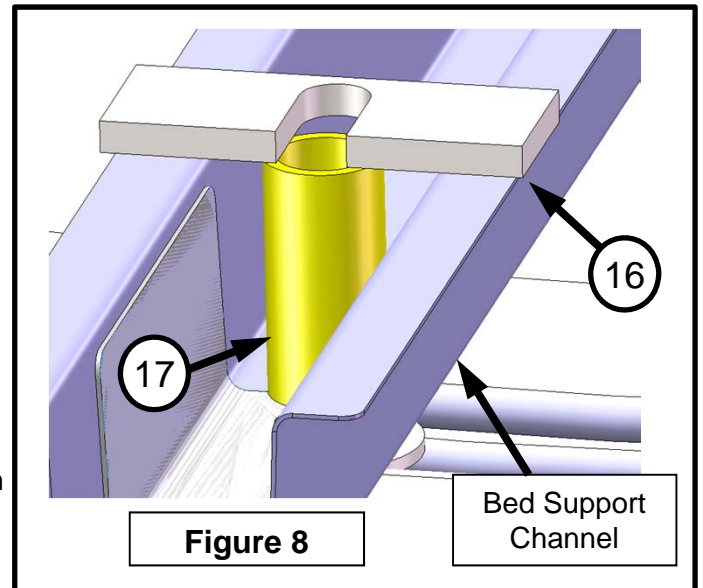

**INSTALL THE BRACKET CAREFULLY. DO NOT LET IT RUB PLASTIC LINES. SEE FIGURES 5, 6 & 7**

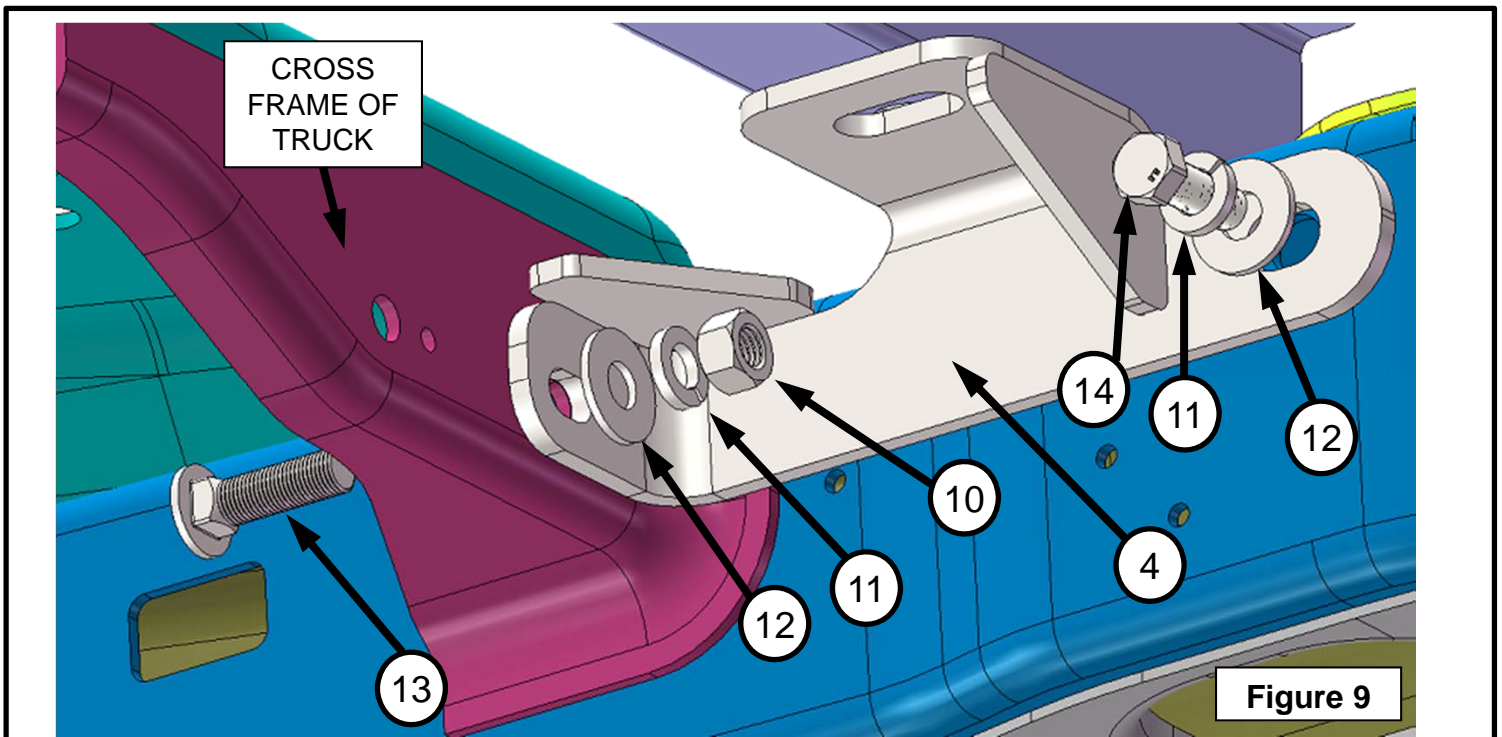

**TRUCK WIRING AND BRAKE LINES REMOVED FROM DIAGRAM FOR CLARIFICATION PURPOSES**

18. Repeat steps 14 through 17 for passenger side front bracket (item #1).

**WARNING:**

**IF THE TRUCK HAS THE OEM 5<sup>TH</sup> WHEEL PREP PACKAGE; THE REAR “PUCKS” MUST BE REMOVED 1<sup>ST</sup> BEFORE INSTALLING THE REAR BRACKETS SUPPLIED IN THIS INSTALLATION KIT.**

**SEE PAGE 12 FOR OEM 5<sup>TH</sup> WHEEL PREP PACKAGE REMOVAL.**

19. Finally, drill the rear two 3/16 holes from step 13 out to 11/16” using the 3/16” holes as a guide.
20. Install the rear driver’s side bracket (item #3) using the 12mm bolt and 1/2” washers (items #11,12 &14) into the 12mm tapped holes in the rear of the frame. See figure 10. Hand tighten hardware only.

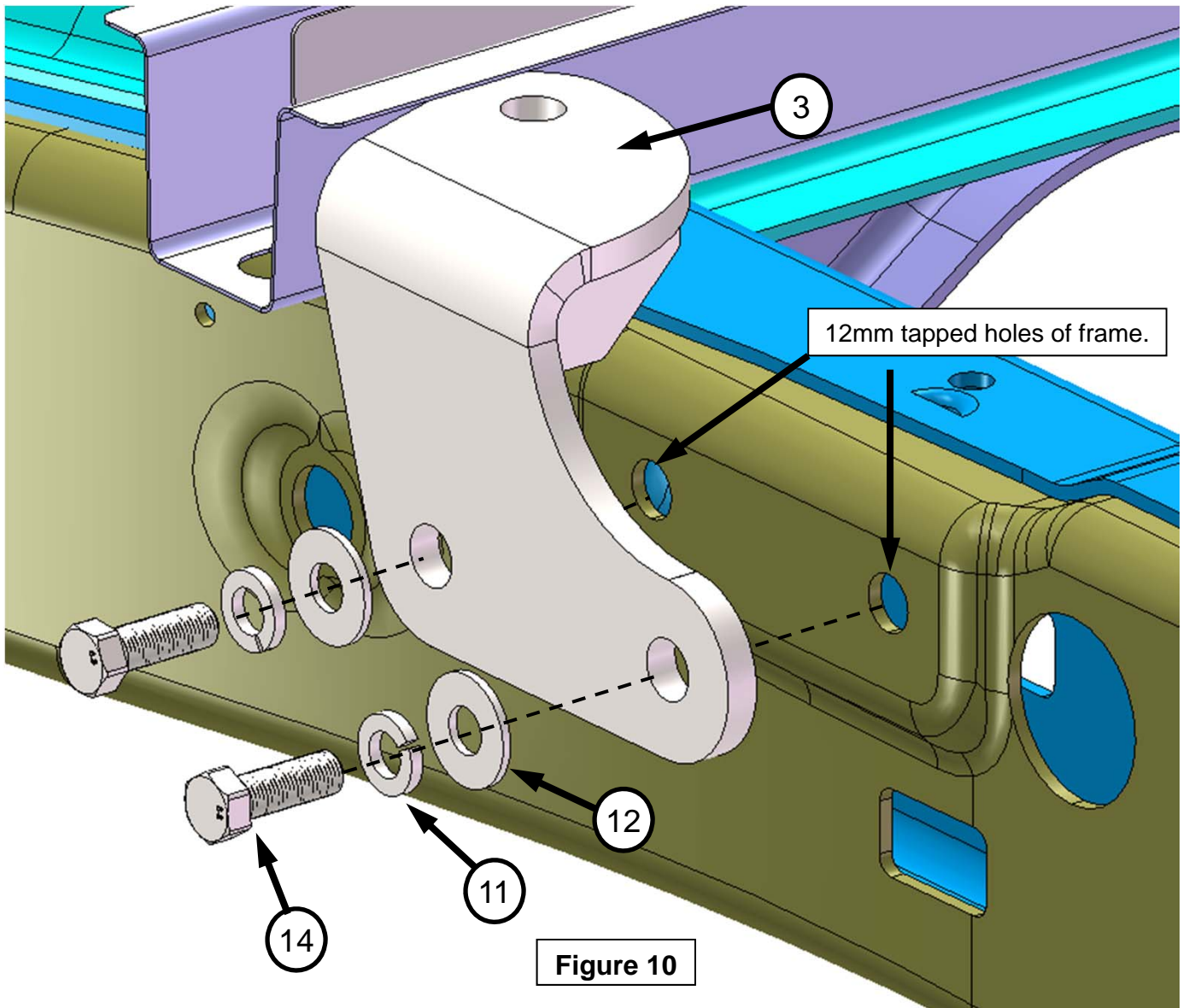

21. Repeat steps 19 & 20 for passenger side rear bracket.



22. Place the two bed rails and 5<sup>th</sup> wheel assembly from steps 10 -13 over the holes drilled in step 13. Secure the front base rail to the front driver's side bracket (item 4) using the 5/8" hardware (items 5,15,16, 17, 6, 7 & 8). Install the base rail spacer (item#15) as shown. Install the 1/4" spacer (item #16) as shown between the truck bed and the front driver side bracket. See Figures 11 & 12. Hand tighten ONLY 5/8" hardware. Reinstall "Christmas Tree clip" with plastic lines after bracket install. See Figure 5 on Page 6.

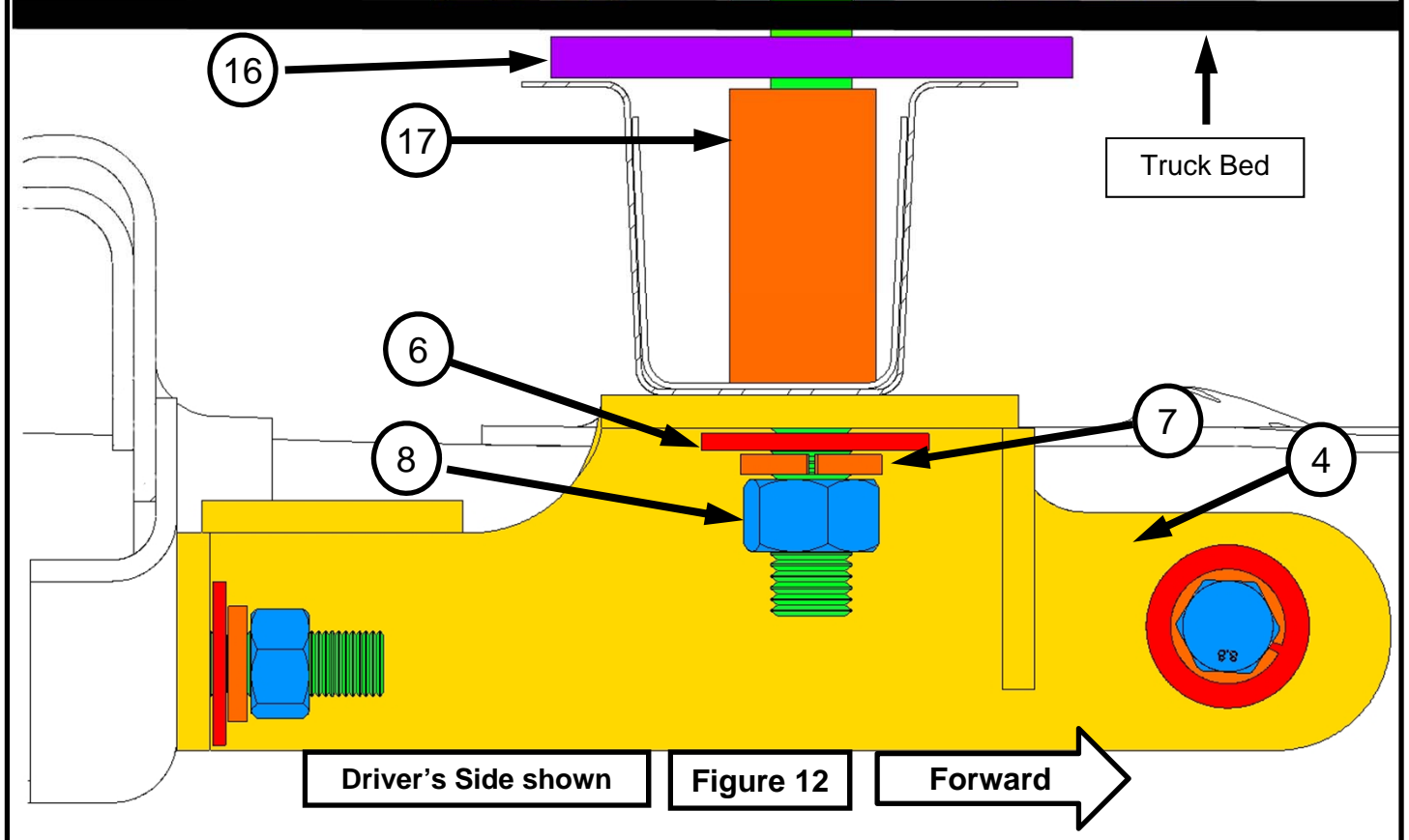
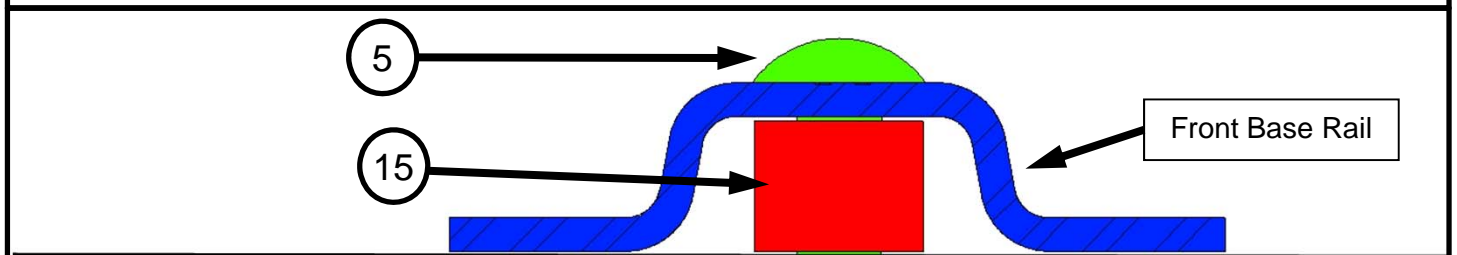
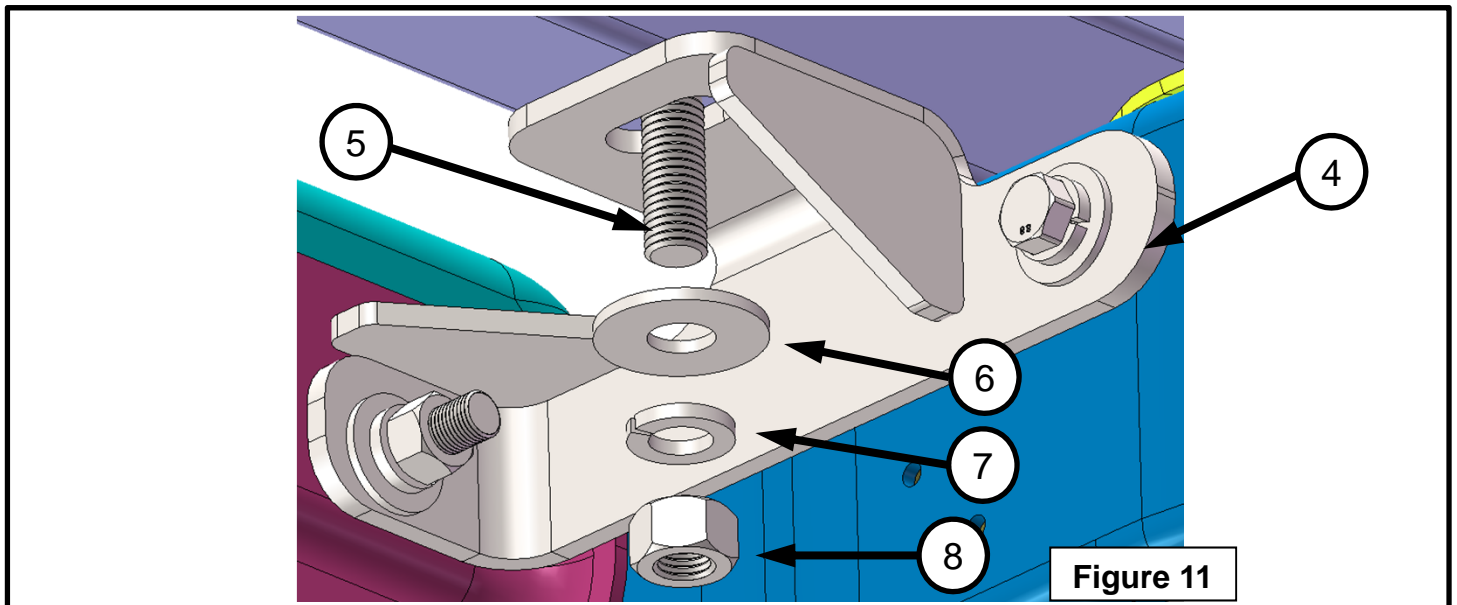

23. Repeat step 22 for passenger side front bracket.

24. Secure the rear base rail to the rear driver's side bracket (item 3) using the 5/8" hardware (items 5, 6, 7, 15, & 16) Install the base rail spacer (item#16) as shown. Hand tighten ONLY 5/8" hardware. See Figure 13.

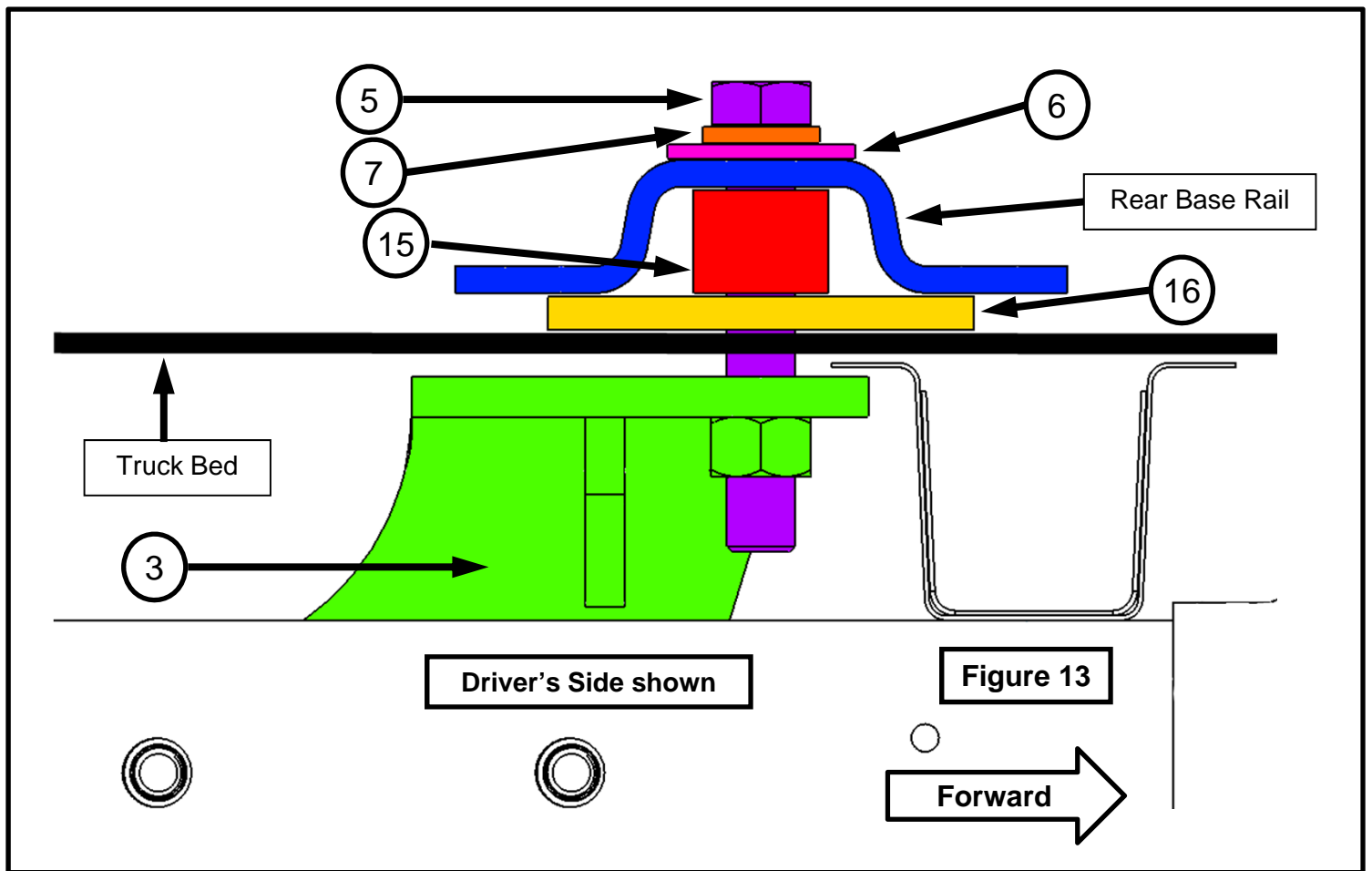

25. Repeat step 24 for passenger side rear bracket (item 2).

26. Torque all hardware to specified specifications listed below and on page 1.

12mm to 70 lb-ft

1/2" to 75 lb-ft

5/8" to 150 lb-ft

27. Finally, Install cross member and ensure it is centered and straight by shimming (if necessary) and then torque bolts to the required value. See 5<sup>th</sup> wheel manufacturer for specifications. Note: Multiple Shims can be stacked together if gap width is large. Use shim kit 31582 or 32043.

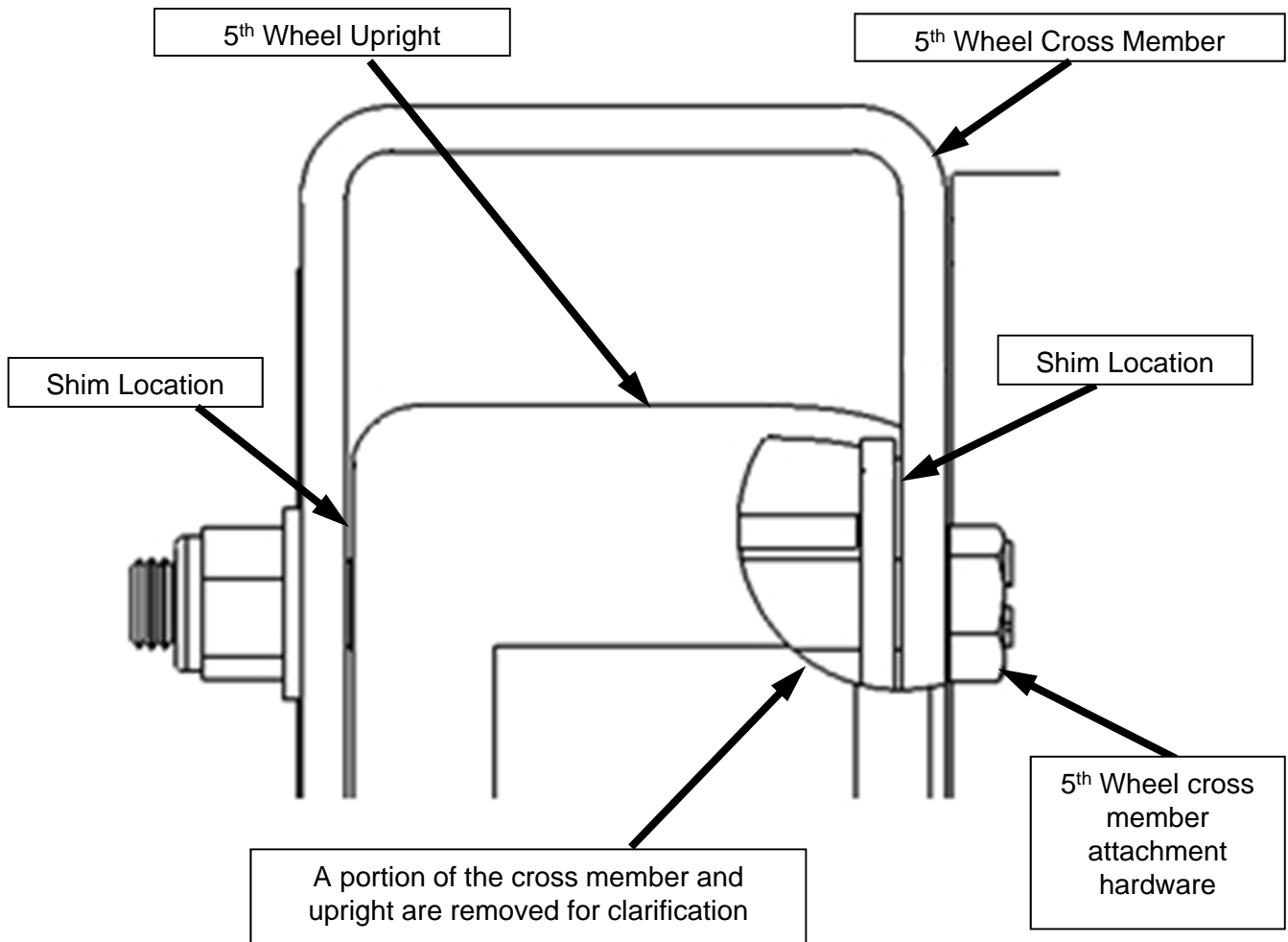

## OEM 5<sup>TH</sup> WHEEL PREP PACKAGE REMOVAL.

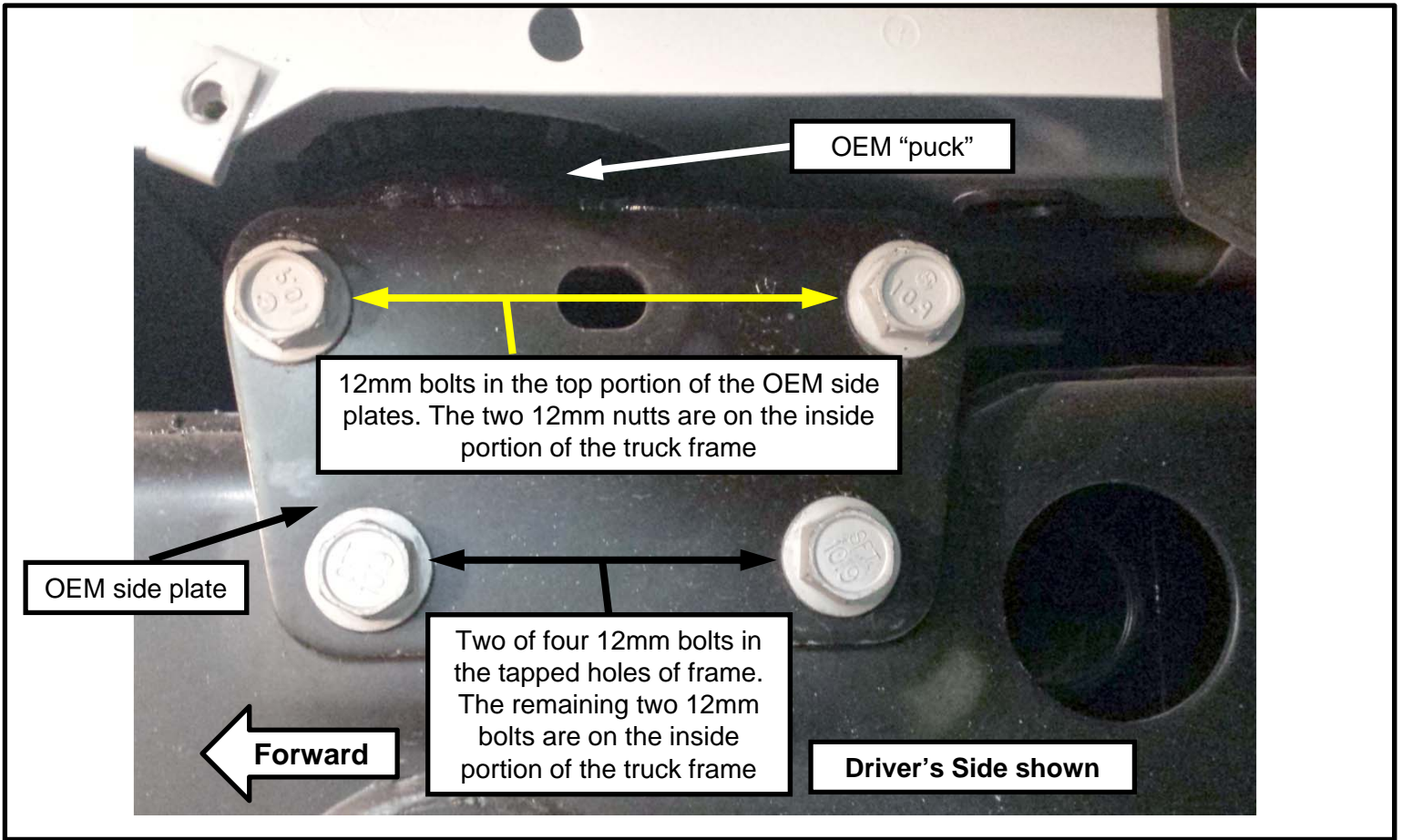

OEM #1: Remove the four 12mm bolts from the tapped holes in the truck frame.

OEM #2: Remove the two 12mm bolts and nuts from top portion of the OEM side plates.

OEM #3: Remove the two side plates.

OEM #4: Remove the "puck". Lifting the truck bed a little may be necessary for removal of "puck".

OEM #5: Repeat for opposite side of truck

